

Hydraulics and How Backflow Happens
Paul H. Schwartz – USC FCCCHR
12 November 2008

**Ontario
Backflow
Prevention
Association**

**Backflow
Seminar**

Paul H. Schwartz, P.E.
Chief Engineer
Foundation for Cross-Connection Control
and Hydraulic Research

12 Nov 2008



Presentation

Hydraulics and How Backflow Happens

Normal view of a hydraulics lecture

Communicate Effectively

- Consider your audience
- General knowledge of water distribution systems
- Previous misunderstandings

EPA Presentations – January 2008

- What we know about backflow
– Including basic hydraulics animation
- What we don't know about backflow,
and the research needs

Hydraulics and How Backflow Happens

Paul H. Schwartz – USC FCCCHR
12 November 2008

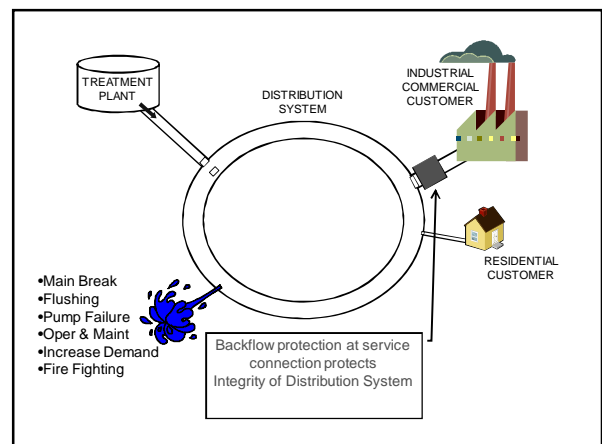
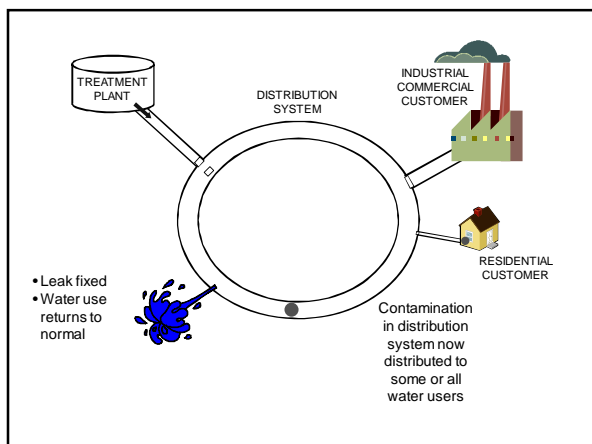
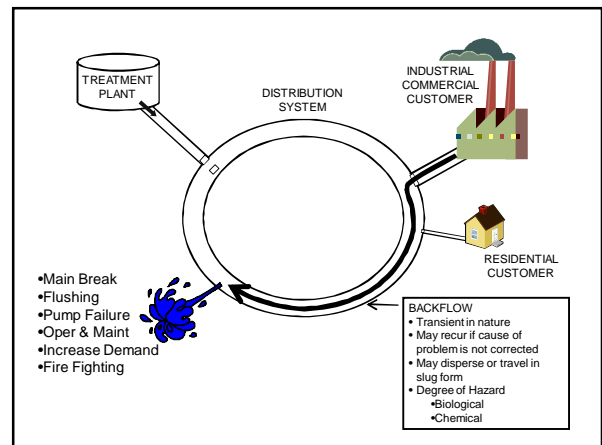
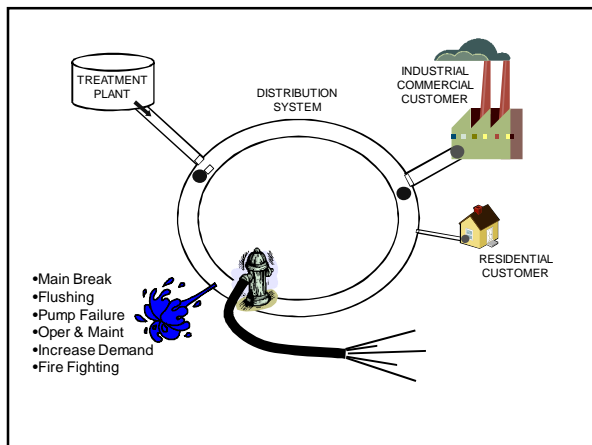
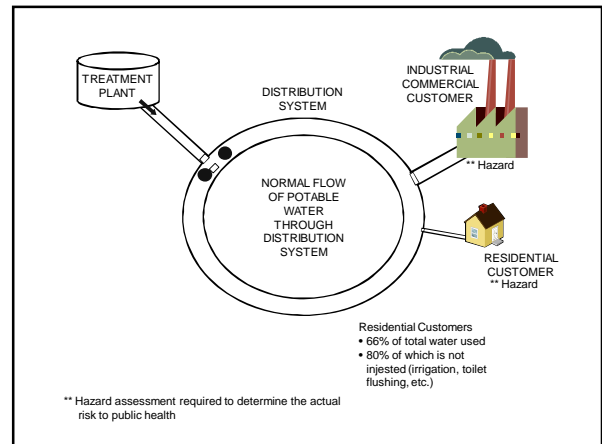
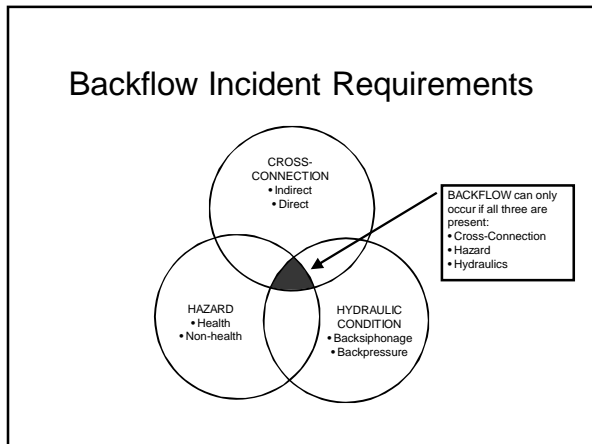

Hydraulics and How Backflow Happens
Paul H. Schwartz – USC FCCCHR
12 November 2008

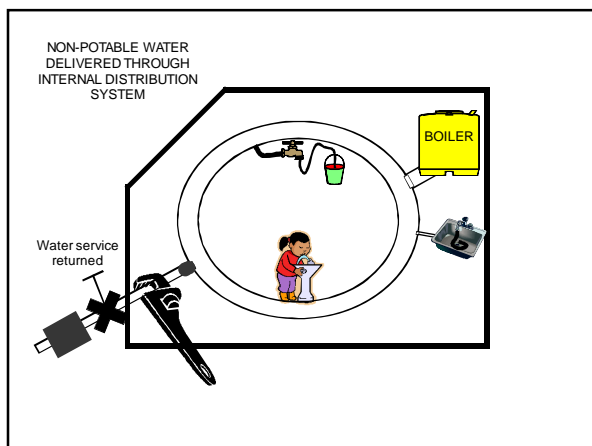
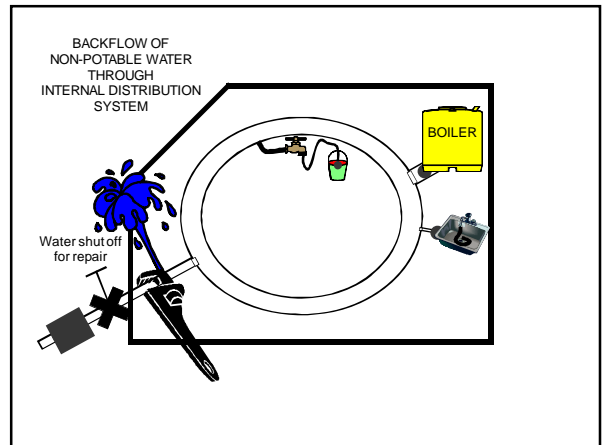
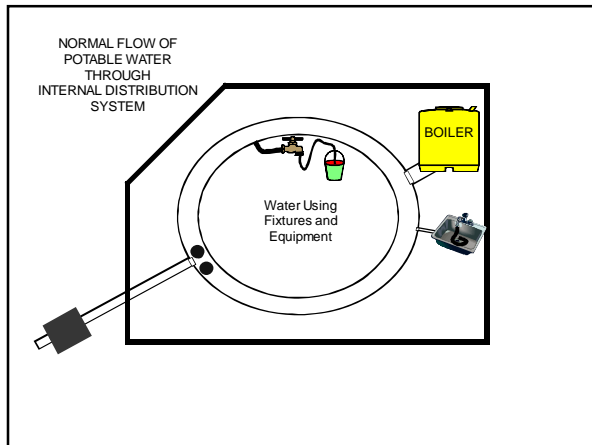
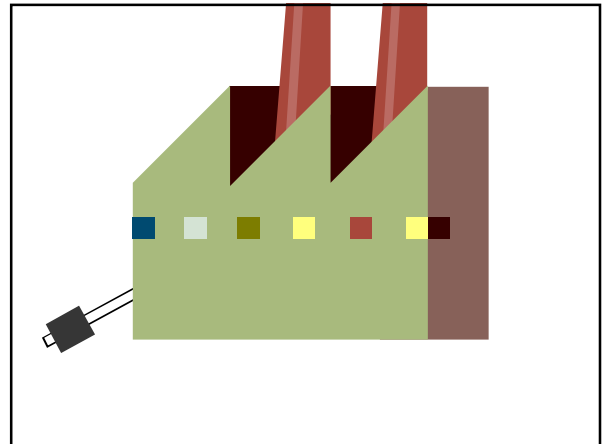
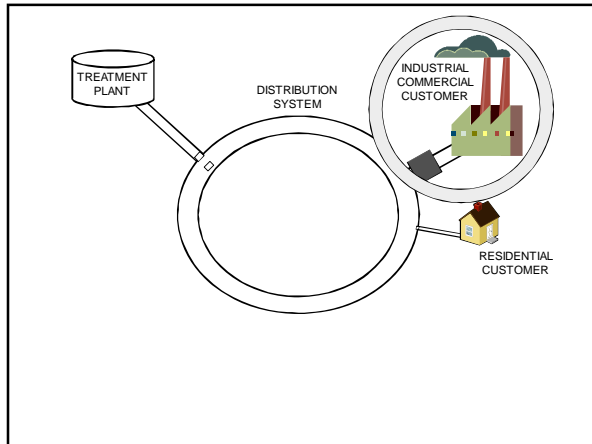

- Today's Overview**
- Hydraulic Principles
 - Hydraulics and Backflow
 - Hydraulics and Backflow Prevention Assemblies

Hydraulics and How Backflow Happens

Paul H. Schwartz – USC FCCCHR
12 November 2008

Hydraulics

- Backflow is all about Hydraulics
- Backflow is not typically taught in hydraulics courses (i.e., don't blame the engineers !)

My Boss
Dr. J.J. Lee
Director, FCCCHR



Backflow is generally caused by a Difference in Pressure

- Backsiphonage
- Backpressure

Example

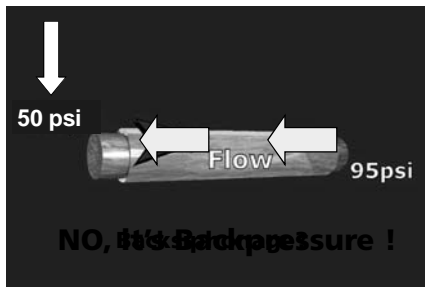

Example #2

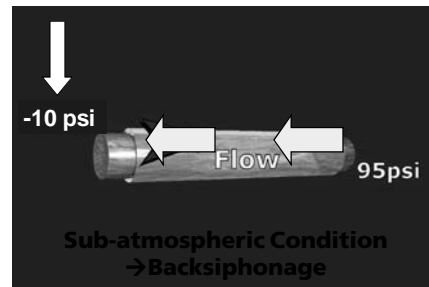

Conclusion

Water always flows from a higher pressure to a lower pressure

NO

Common Misunderstanding

- 60-70% of Engineers taking Professional Engineering Exam miss that question
- Confirms P.E. stands for Partially Educated

Hydraulics and How Backflow Happens
Paul H. Schwartz – USC FCCCHR
12 November 2008

Conclusion Should Be...

Water always flows from a higher energy region to a lower energy region

Bernoulli's Equation

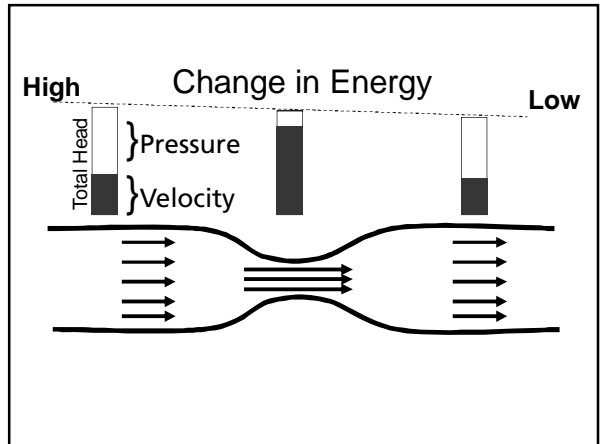
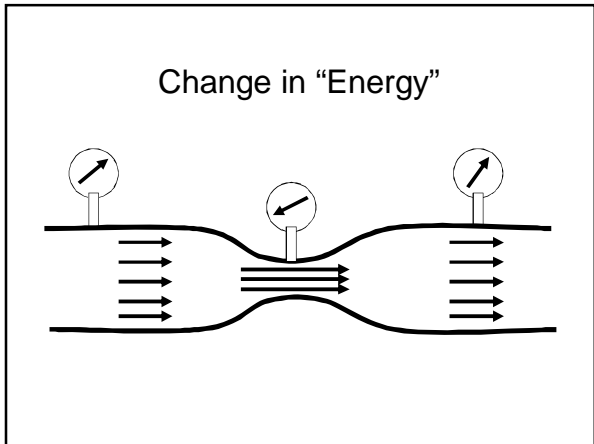
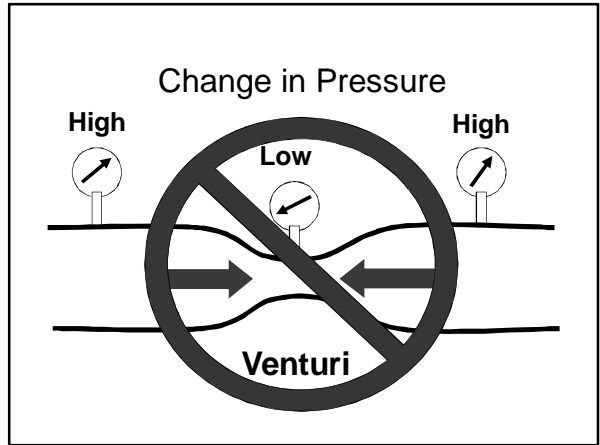
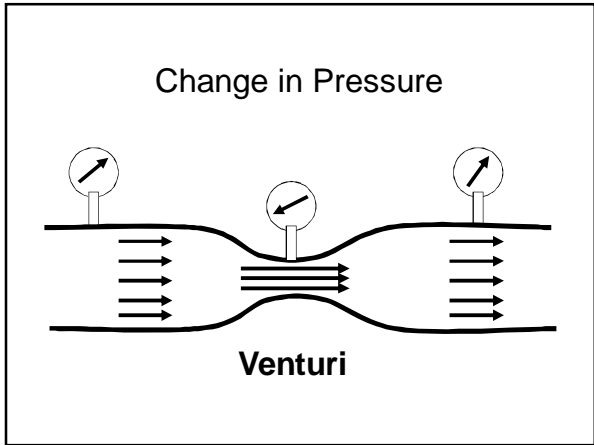
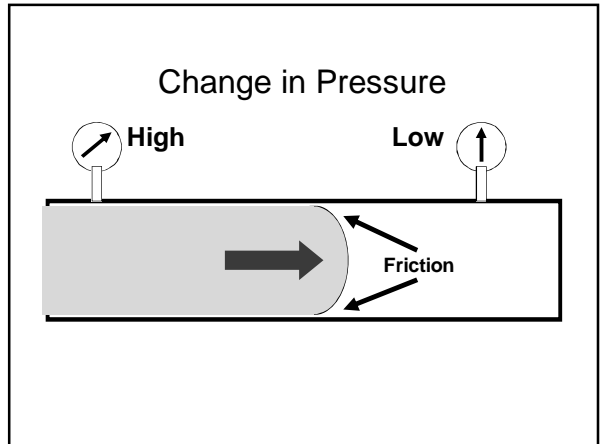

Hydraulics and How Backflow Happens
Paul H. Schwartz – USC FCCCHR
12 November 2008

Hydraulics in Plumbing

Simple plumbing experiences pressure loss due to friction

Hydraulics in Plumbing

Adding Elbows and Tees, etc. will create more pressure loss.

Hydraulics in Plumbing

- Elevation in piping can be a large factor in pressure loss too.
 - Elevation Head (Z)

Hydraulics in Plumbing

- Fixed orifice or opening
 - Pipes
 - Fittings
 - Valves

Hydraulics in Plumbing

- Pressure loss can be identified by C_v
 - Valve constant
 - Characteristic of each type and size valve.

Hydraulics in Plumbing

- Pressure loss can be identified by C_v
 - Valve constant
 - Characteristic of each type and size valve.

Hydraulics and How Backflow Happens
Paul H. Schwartz – USC FCCCHR
12 November 2008

Hydraulics in Backflow Prevention Assemblies

- Backflow prevention assemblies don't have fixed openings/orifices
- Check valves are biased closed
 - Weight loaded
 - Spring loaded

Hydraulics in Check Valves

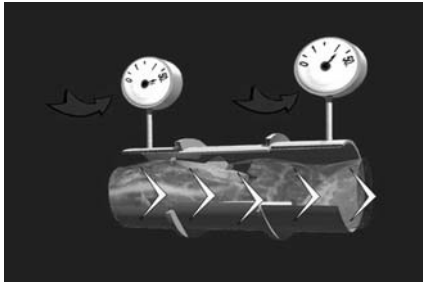

Hydraulics in Check Valves

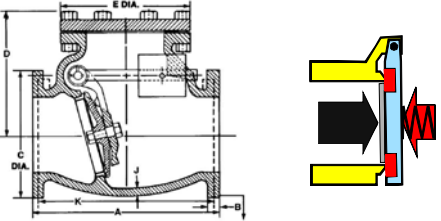

Hydraulics in Check Valves

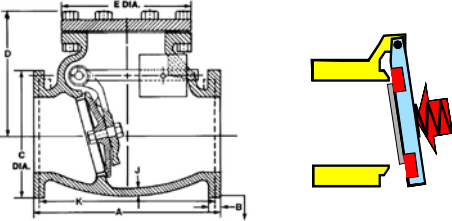

Hydraulics in Check Valves

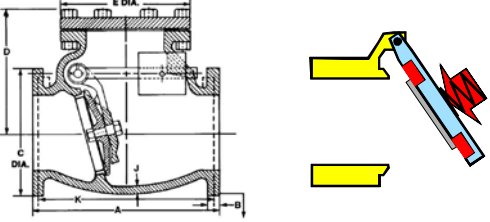

Hydraulics in Check Valves

Misconception – Checks open fully

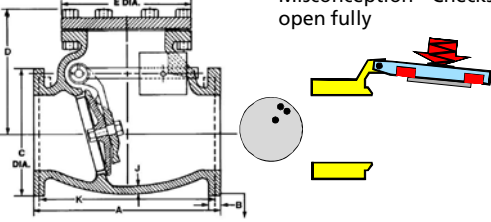

Hydraulics and How Backflow Happens
Paul H. Schwartz – USC FCCCHR
12 November 2008

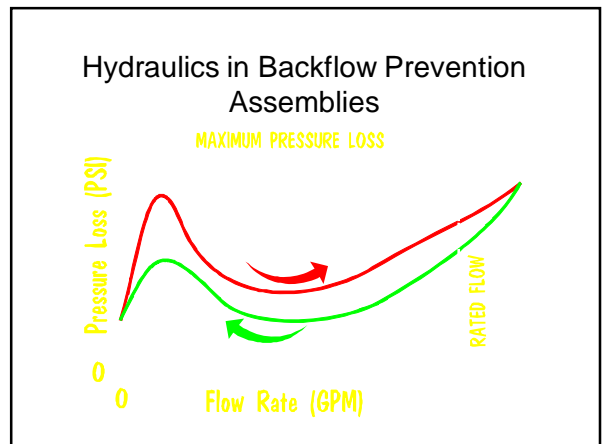
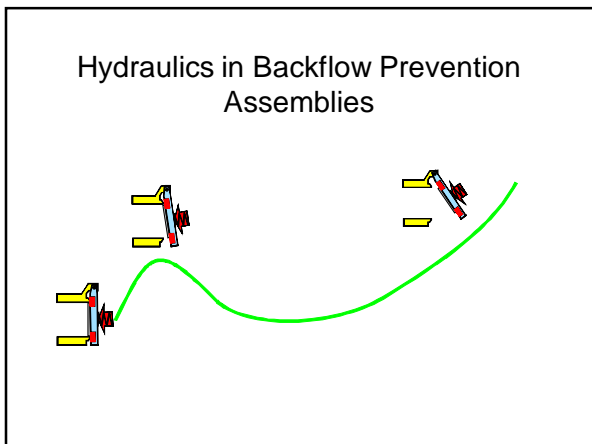
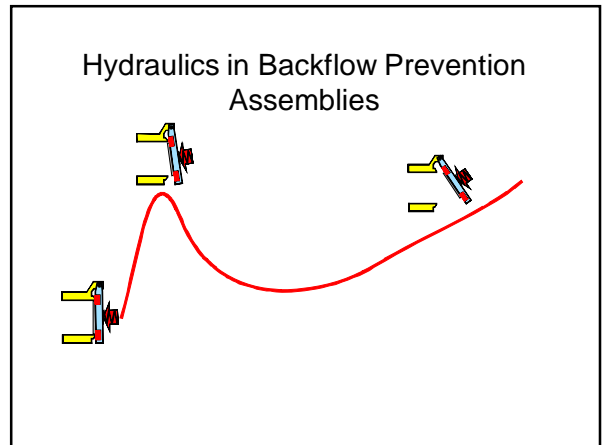
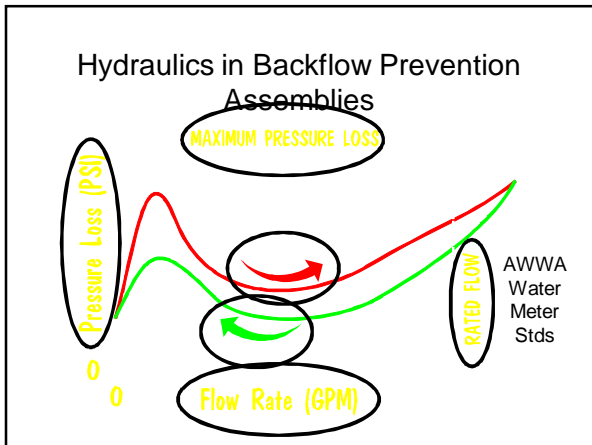
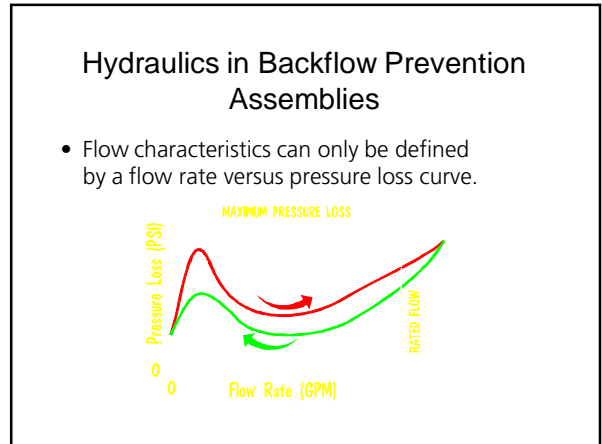
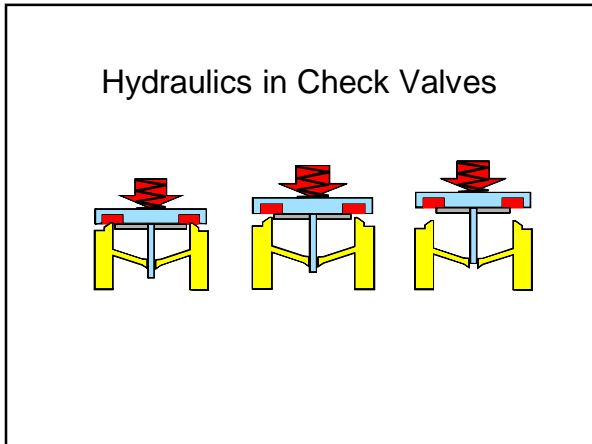

Hydraulics and How Backflow Happens
Paul H. Schwartz – USC FCCCHR
12 November 2008

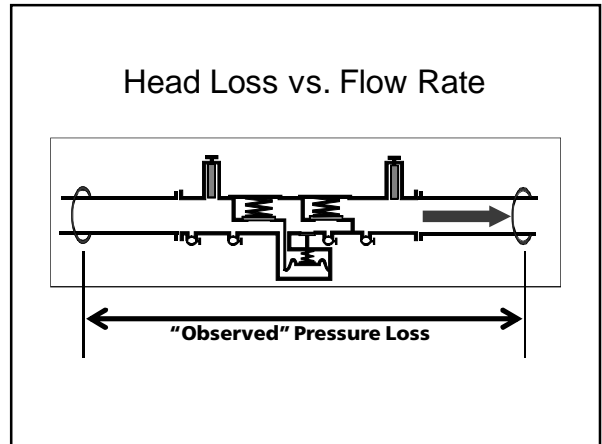
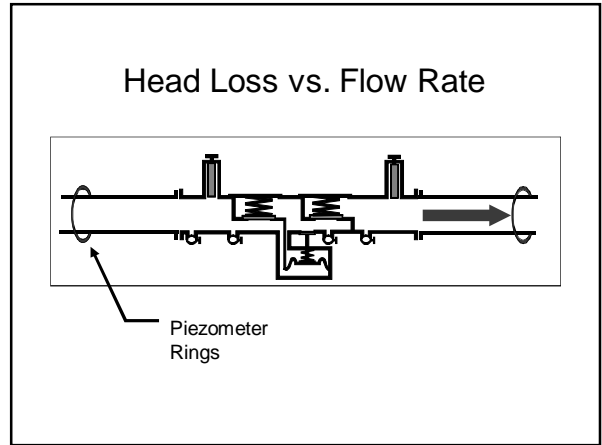
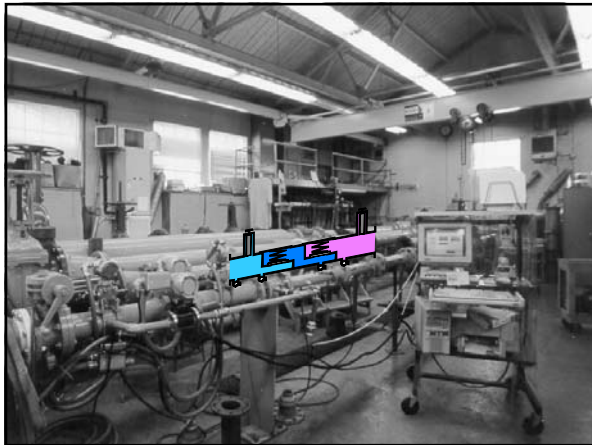
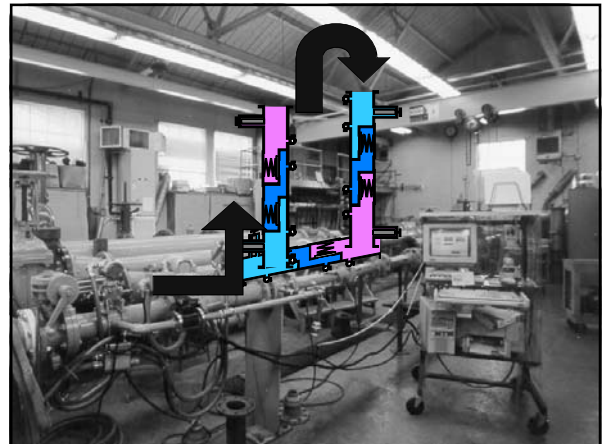
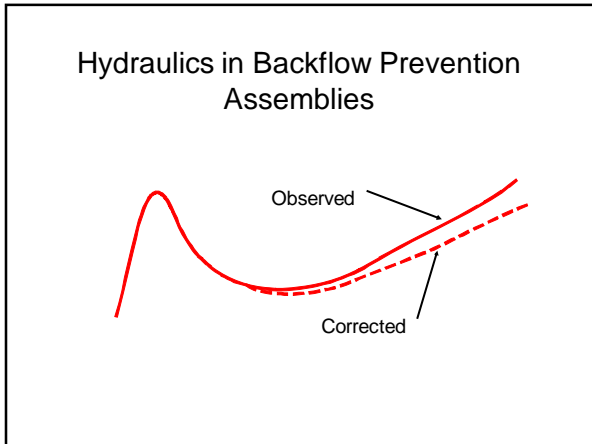

Hydraulics and How Backflow Happens
Paul H. Schwartz – USC FCCCHR
12 November 2008

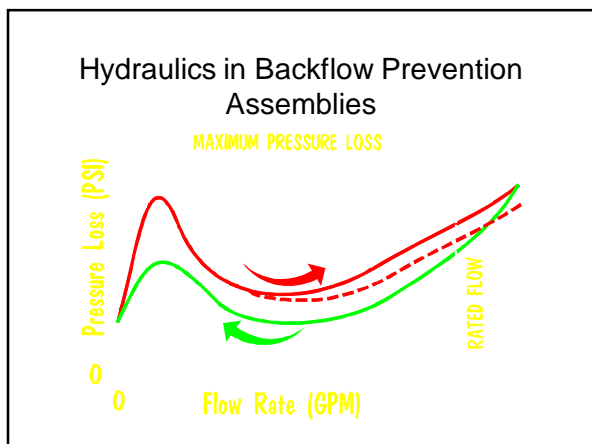
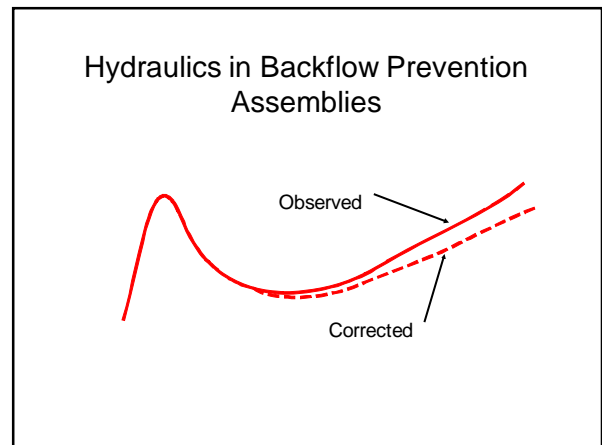
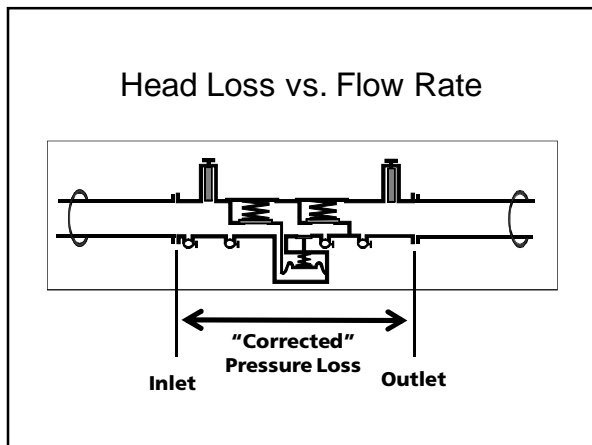
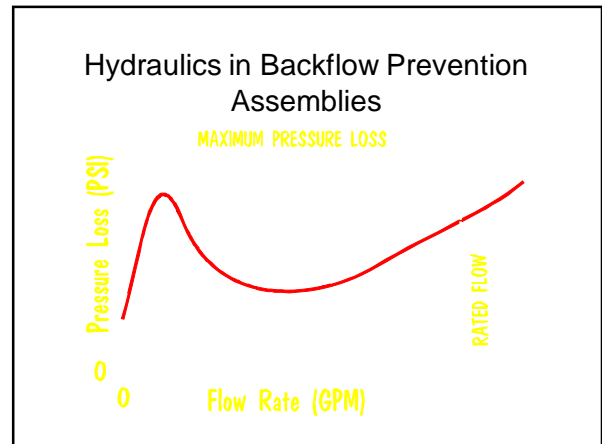
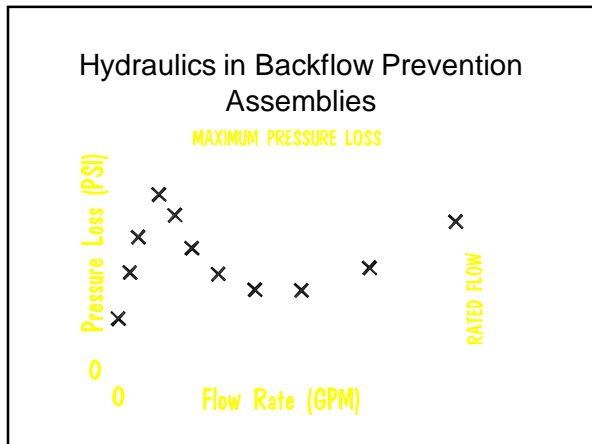

- Over sizing of Assemblies**
- Bigger means better?
 - Affects operation of assembly?

Hydraulics and How Backflow Happens
Paul H. Schwartz – USC FCCCHR
12 November 2008

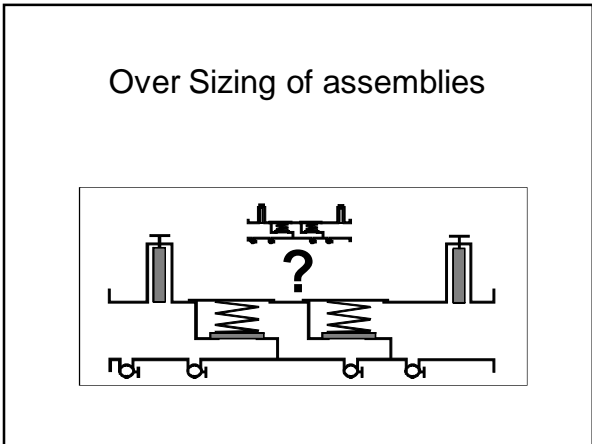

- Adequate flow and pressure?
- Oversize backflow preventer
 - Provide more water?
 - Provide more pressure?
 - Compare flow curves

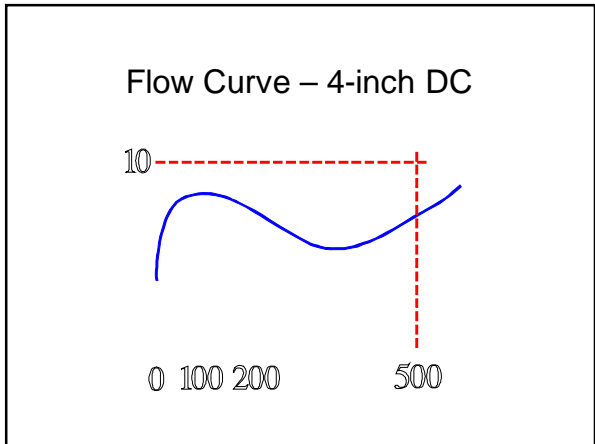
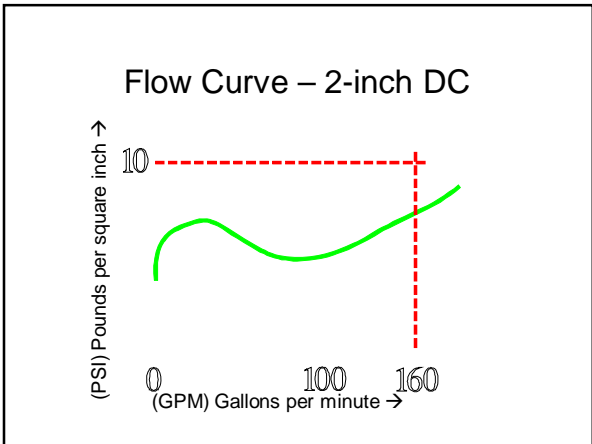
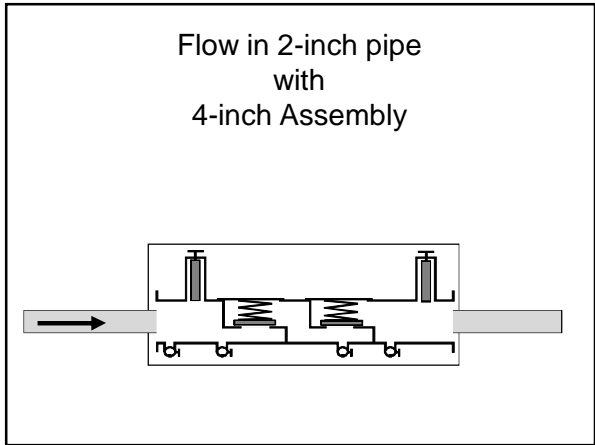
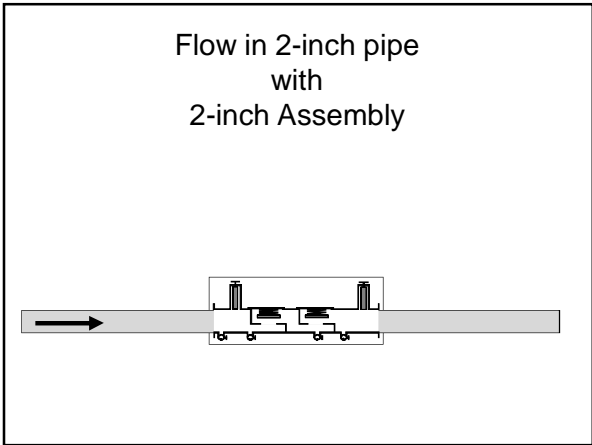

Hydraulics and How Backflow Happens
Paul H. Schwartz – USC FCCCHR
12 November 2008

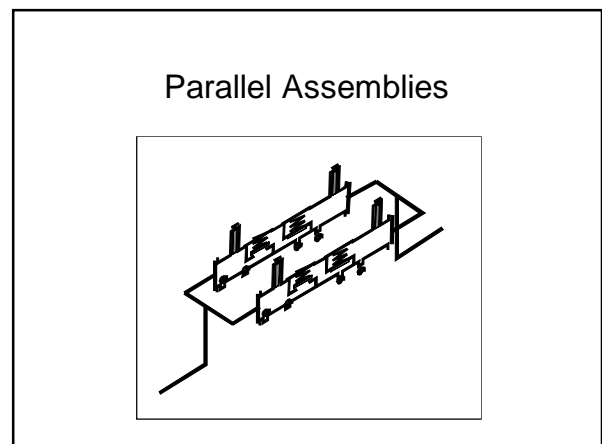
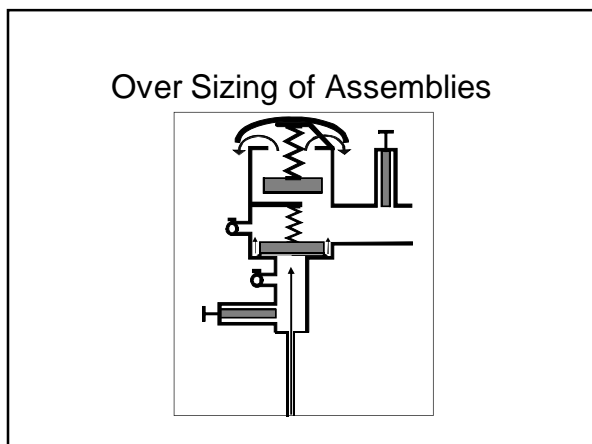
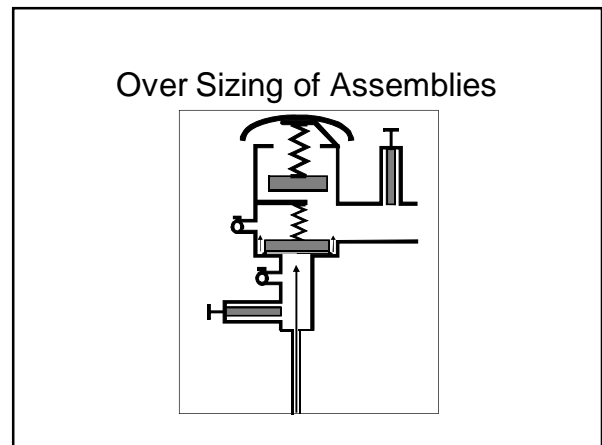
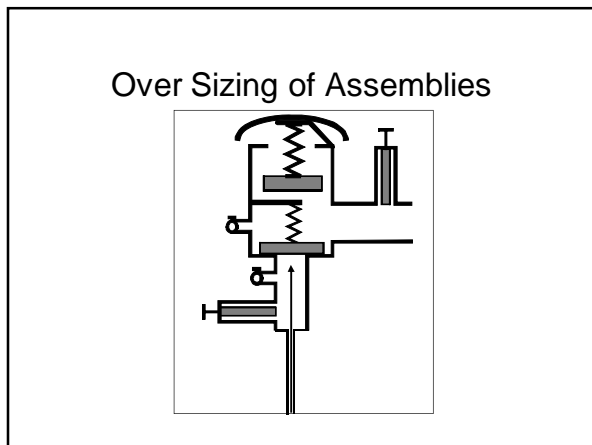
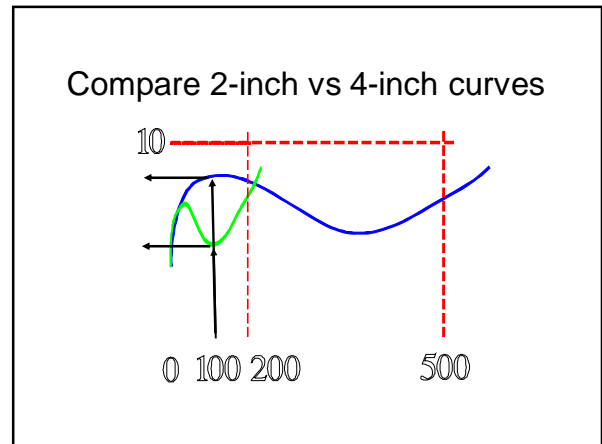
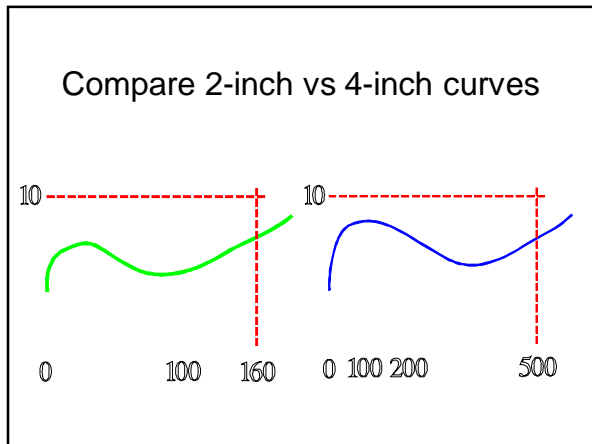

Hydraulics and How Backflow Happens
Paul H. Schwartz – USC FCCCHR
12 November 2008

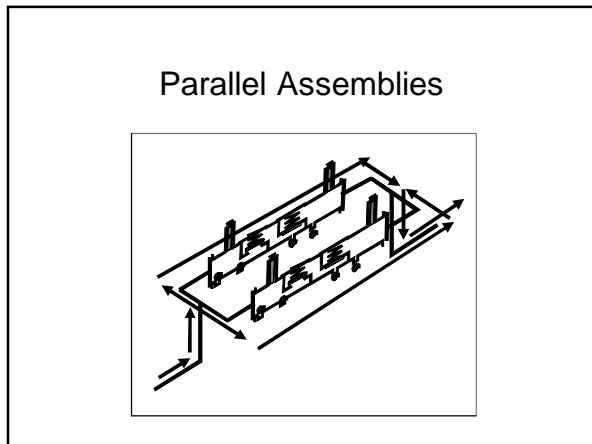

Parallel Assemblies

- Operate independently
 - Primary
 - Secondary
- Path of least resistance
 - No two assemblies are identical
- Maintenance/Repair records may differ

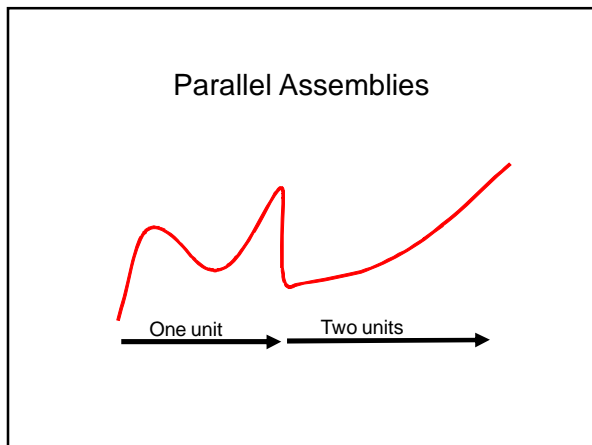

Hydraulics

- Backflow and Backflow Prevention are all about Hydraulics
- Much more info can be covered
- Presentations
 - Size-up your audience appropriately
 - Don't assume they understand even the basic hydraulic issues about backflow

Manual - 10th Edition

- Chapter 3
 - Hydraulics
 - Properties of fluids
 - Principles of backflow
 - Operation of backflow preventers
 - Detailed operating characteristics of DC, RP, PVB, SVB
 - Head loss vs flow rate curves
 - Parallel installations

Chapter 3 - Hydraulics

- Properties of water

Hydraulics and How Backflow Happens
Paul H. Schwartz – USC FCCCHR
12 November 2008

Chapter 3 - Hydraulics

- Operation of check valves

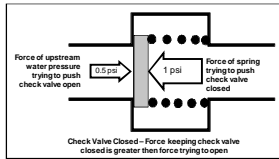

Chapter 3 - Hydraulics

- Operation of check valves

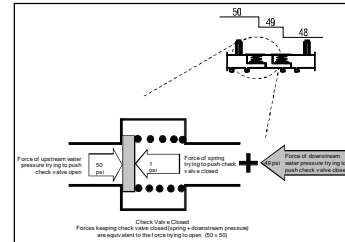

Chapter 3 - Hydraulics

- Operation of components in RP

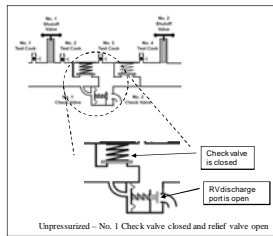

QUESTIONS